



Service Bulletin

SB 07-05

Issued: 8-24-07

Flight Design CT BRS Activation Handle Inspection & Rework

Compliance

Mandatory: BRS considers this service bulletin to be mandatory. The BRS system is deemed inoperable until compliance with this Service Bulletin has been met.

Effectivity

All Flight Design CT aircraft equipped with a BRS parachute system using a Phillips head screw to mount the activation handle. This service bulletin does not apply to systems using a tamper proof screw to mount the activation handle (see illustrations).



Phillips head screw
Inspection required



Tamper proof screw
No inspection required

Purpose

Some airplanes may have a BRS activation handle assembly in which the screw that attaches the mounting plate to the handle holder was removed and improperly reassembled. This could result in a situation in which the system may not operate when the activation handle is pulled.

Description

This Service Bulletin provides for the inspection and proper reassembly of the BRS activation housing.

Warranty Information

N/A

Manpower Requirements

0.5 to 1.0 man hours

Weight and Balance

N/A

Material Information

N/A

Accomplishment Instructions

Note: Please read and understand the following instructions in their entirety before performing the work.

1. Acquire necessary tools, equipment and supplies.
 - a. Phillips screwdriver
 - b. Flashlight
 - c. Removable thread locker
2. Remove key from ignition
3. Open baggage door to gain access to parachute canister/rocket motor. Remove the plastic cap plug from the rocket cone at the base of the rocket motor. Remove the screw that secures the activation cable loop to the rocket igniter.



4. Unscrew the rocket cone adapter from the rocket cone.



5. Remove safety flag from activation handle.
6. Remove the activation handle from its holder.



7. Using the flashlight, look into the open end of the activation handle holder. If the system was properly assembled, a screw should be visible in front of the nylon retaining nut. If the screw is visible in front of the nylon nut, skip to step 11.



Correct. Screw is visible!

8. If the system was improperly assembled, the screw will not be visible.



Incorrect. Screw is not visible!

9. The nylon nut is used to secure the activation cable housing in place when the activation handle is pulled. If the screw is not holding the nylon nut inside the handle holder, the activation cable can be pulled out of the handle holder when the handle is pulled. This could prevent the pull force from being transferred to the rocket motor igniter.

THIS IS NOT CORRECT!
(nut front side of retain screw)

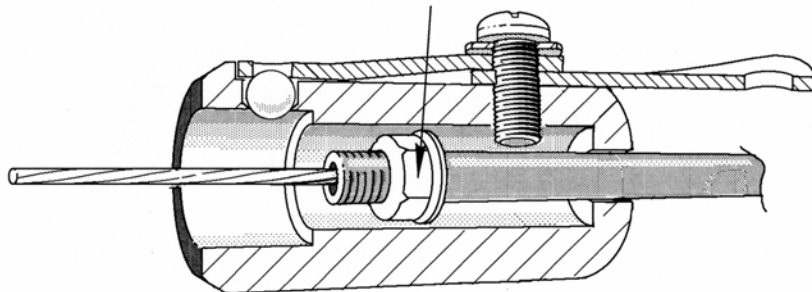

10. If the retaining screw is not properly located, it must be reinstalled. Remove the retaining screw from the handle holder while taking care to retain the detent ball, mounting plates, and washer. Pull the nylon nut towards the back inside surface of the handle holder by gently pulling on the cable housing. Wet the screw with threadlocker and reinstall. Ensure that the nylon nut is behind the screw.

Note: Actual mounting hardware will vary between aircraft models and may not look like the depiction in the sketch. However, the retaining screw configuration is the same for all models.

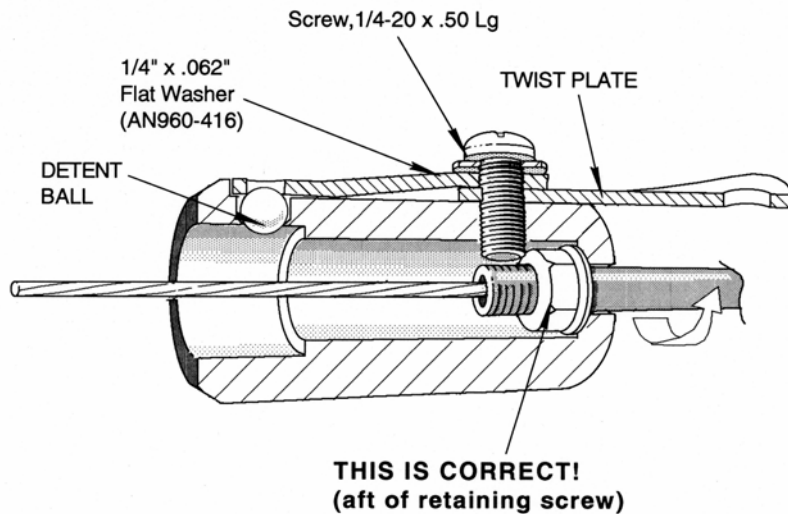

Note: The washer must also be installed. Otherwise, the retaining screw could protrude too far inside the handle holder and crush the cable housing. This could create excessive pull forces when attempting to activate the system. Check this by rotating the cable housing approximately one half turn in each direction to ensure that it is not restricted.

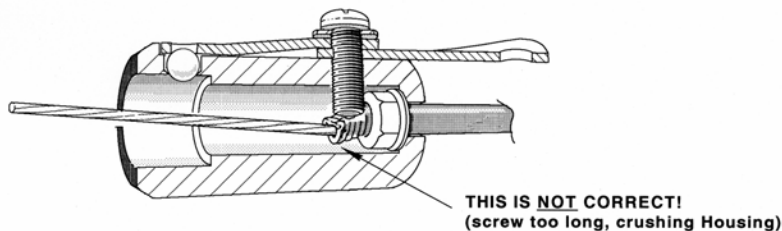

11. Reinsert activation handle into activation handle holder.
12. Insert safety flag in activation handle.

13. Insert the activation cable loop in the slot of the rocket igniter at the base of the rocket motor. Reinstall screw with threadlocker. Reinstall plastic cap plug.



Photos show rocket cone 'cut-away' in order to show cable attachment more clearly.

Install rocket cone prior to attempting to attach activation cable.



Grasp activation cable as shown and insert into threaded end of rocket cone. You must do this while peering through access hole on side of cone. You may need to use a flashlight.



Insert loop into slot in base of rocket actuator.

Warning ! This is very important! The cable MUST be installed with the loop fitted to the slot.

Failure to do so may lead to deployment failure which may cause death or severe injury.



Actuating cable loop properly fitted into slot.



Secure cable loop by installing screw and washer. Be careful to ensure that screw passes through cable loop and is not pinching or crushing cable.



Very slowly and gently, tug on the steel stranded cable to ensure that the screw has captured the cable loop. See photos below for improper assembly.

Caution:

Do not pull hard enough to move the screw used to capture the cable loop. Doing this could activate the rocket, causing death or serious injury!!

Warning!! The cable must be inserted into the slot and not to either side!!



Captured only by exposed screw threads on back side of actuator. In danger of slipping off of screw completely.

Captured by screw on front side of actuator.

14. Thread rocket cone adapter to the rocket cone.



Install cone adapter to cone by screwing it on. Install hand tight.



Final Procedure

Complete aircraft records by noting compliance with BRS SB 07-05 in aircraft logbook. Send completed Compliance Response form to BRS Inc.

Ballistic Recovery Systems, Inc.

**Compliance Response Form
for
Service Bulletin 07-05**

Flight Designs CT

It is necessary that BRS maintain a record of all airplanes in compliance with the requirements of this Service Bulletin. Additionally, BRS requires that this Service Bulletin response form be completed and returned.

Airplane Information

Airplane Information: _____

Serial Number: _____

Hour Meter Reading: _____

Service Facility Information

Service Facility Name: _____

Compliance Information

BRS Service Bulletin 07-05 was complied with on the referenced serial number airplane at the listed airplane hours.

Signature: _____

Title: _____ Date: _____

Comments: _____

Return form to:

BRS, Inc.
Quality Control Manager
300 Airport Road
South St. Paul, Minnesota 55075