

SERVICE BULLETIN

INSPECT FOR TIGHT FIT OF OIL FILTER

FOR ROTAX® ENGINE TYPE 912 AND 914 (SERIES)

SB-912-055 UL

SB-914-036 UL

MANDATORY

Repeating symbols:

Please, pay attention to the following symbols throughout this document emphasizing particular information.

- ▲ **WARNING:** Identifies an instruction, which if not followed, may cause serious injury or even death.
- **CAUTION:** Denotes an instruction which if not followed, may severely damage the engine or could lead to suspension of warranty.
- ◆ **NOTE:** Information useful for better handling.

1) Planning information

1.1) Engines affected

All versions of the engine type:

- 912 UL from S/N 4,408.413 to S/N 4,408.820
- 912 ULS from S/N 5,648.511 to S/N 5,649.505
- 912 ULSFR from S/N 6,374.084 to S/N 6,374.189
- 914 UL from S/N 4,419.688 to S/N 4,419.896

In addition, are also affected, all engines with oil filter part no. 825701/825703, has installed from July 01st2007 to September 01st2007, at engine maintenance/repair/general overhaul.

For complete instructions and compliance to this Service Bulletin refer to Service Bulletin SB-912-055 and SB-914-036, latest edition section 1.2 onward.

- ◆ **NOTE:** Section 1.6) Approval: Is not required for engines of the type UL (series).
Section 3) Accomplishment: In addition: persons with adequate type-specific training.

SERVICE BULLETIN

INSPECT FOR TIGHT FIT OF OIL FILTER FOR ROTAX® ENGINE TYPE 912 AND 914 (SERIES)

SB-912-055

SB-914-036

MANDATORY

Repeating symbols:

Please, pay attention to the following symbols throughout this document emphasizing particular information.

▲ **WARNING:** Identifies an instruction, which if not followed, may cause serious injury or even death.

■ **CAUTION:** Denotes an instruction which if not followed, may severely damage the engine or could lead to suspension of warranty.

◆ **NOTE:** Information useful for better handling.

1) Planning information

1.1) Engines affected

All versions of the engine type:

- 912 A from S/N 4,410.738 to S/N 4,410.774
- 912 F from S/N 4,412.927 to S/N 4,412.938
- 912 S from S/N 4,923.476 to S/N 4,923.574
- 914 F from S/N 4,420.704 to S/N 4,420.747

In addition, are also affected, all engines with oil filter part no. 825701/825703, has installed from July 01st2007 to September 01st2007, at engine maintenance/repair/general overhaul.

1.2) Concurrent ASB/SB/SI and SL

none

1.3) Reason

Due to possible wrong interpretation of the tighten specification leaks or loss of the oil filter could occur. It is necessary to inspect the oil filter for tight fit. In case of doubt the oil filter has to be installed again by means of a simplified and standardized tighten specification.

1.4) Subject

Inspect for tight fit of oil filter for ROTAX® Motor Type 912 and 914 (Series)

1.5) Compliance

- before the next flight

◆ **NOTE:** A delivery flight to a maintenance center is permitted if necessary so long as no leaks found on the oil filter.

▲ **WARNING:** Non-compliance with these instructions could result in engine damages, personal injuries or death.

1.6) Approval

The technical content is approved under the authority of DOA Nr. EASA.21J.048.

1.7) Manpower

Estimated man-hours:

engine installed in the aircraft - - - manpower time will depend on installation and therefore no estimate is available from the engine manufacturer.

1.8) Mass data

change of weight - - - none.
moment of inertia - - - unaffected.

1.9) Electrical load data

no change

1.10) Software accomplishment summary

no change

1.11) References

In addition to this technical information refer to current issue of

- Operators Manual (OM)
- Illustrated Parts Catalog (IPC)
- Maintenance Manual (MM)

◆ NOTE: The status of Manuals can be determined by checking the table of amendments of the Manual. The 1st column of this table is the revision status. Compare this number to that listed on the ROTAX WebSite: www.rotax-aircraft-engines.com. Updates and current revisions can be downloaded for free.

1.12) Other publications affected

none

1.13) Interchangeability of parts

- All parts are interchangeable

2) Material Information

2.1) Material - cost and availability

Price and availability will be supplied on request by ROTAX[®] Authorized Distributors or their Service Center.

2.2) Company support information

none

2.3) Material requirement per engine

parts requirement:

Fig.no.	New p/n	Qty/engine	Description	Old p/n	Application
	825703	1	oil filter	-	oil system

2.4) Material requirement per spare part

none

2.5) Rework of parts

none

2.6) Special tooling/lubricant-/adhesives-/sealing compound

Price and availability will be supplied on request by ROTAX[®] Authorized Distributors or their Service Centers.

parts requirement:

Fig.no.	p/n	Qty/engine	Description	Old p/n	Application
	-	as required	engine oil	-	oil filter

3) Accomplishment/Instructions

Accomplishment

All the measures must be taken and confirmed by the following persons or facilities:

- ROTAX[®] -Airworthiness representative
- ROTAX[®] -Distributors or their Service Centers
- Persons approved by the respective Aviation Authority

▲ **WARNING:** Proceed with this work only in a non-smoking area and not close to sparks or open flames. Switch off ignition and secure engine against unintentional operation. Secure aircraft against unauthorized operation. Disconnect negative terminal of aircraft battery.

▲ **WARNING:** Risk of scalds and burns! Allow engine to cool sufficiently and use appropriate safety gear while performing work.

▲ **WARNING:** Should removal of a locking device (e.g. lock tabs, self-locking fasteners, etc.) be required when undergoing disassembly/assembly, always replace with a new one.

◆ **NOTE:** All work has to be performed in accordance with the relevant Maintenance Manual.

3.1) Inspection of the oil filter

▲ **WARNING:** Always allow the engine to cool down to ambient temperature before starting work. Otherwise you risk getting severely burned or scalded!

1. Inspect for tight fit of oil filter installed on engine.

In case of doubt remove the oil filter and re-install in accordance with section 3.2 and section 3.3.

3.2) Install oil filter

(see Fig. 1)

1. Clean the contact surface (1) of the oil pump housing (2) with a clean cloth.

2. Apply thin film engine oil on the gasket (3) of the oil filter (4) and then install the oil filter on the engine.

3. Screw on oil filter until oil filter gasket is seated solidly.

4. Tighten oil filter with 3/4 turn (270°).

- Restore aircraft to original operating configuration.
- Connect negative terminal of aircraft battery.

3.3) Test run

Conduct test run including ignition check and leakage test in accordance with the current Maintenance Manual of the respective engine type.

■ **CAUTION:** After test run inspect tight fit of oil filter.

3.4) Summary

These instructions (section 3) have to be conducted in accordance with compliance in section 1.5.

The execution of the mandatory Service Bulletin must be confirmed in the logbook.

▲ **WARNING:** Non-compliance with these instructions/recommendations/could result in engine damage, personal injury or death!

Approval of translation to best knowledge and judgement - in any case the original text in German language and the metric units (SI-system) are authoritative.

4) Appendix

the following drawings should convey additional information:

fig. 1

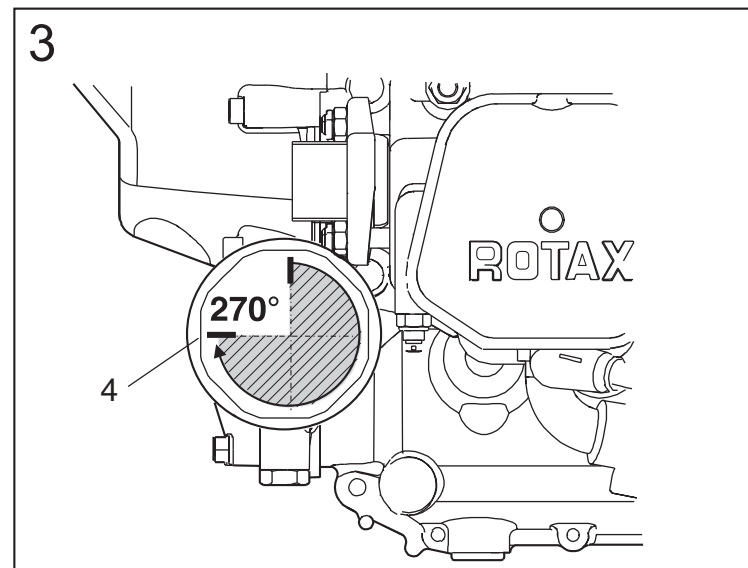
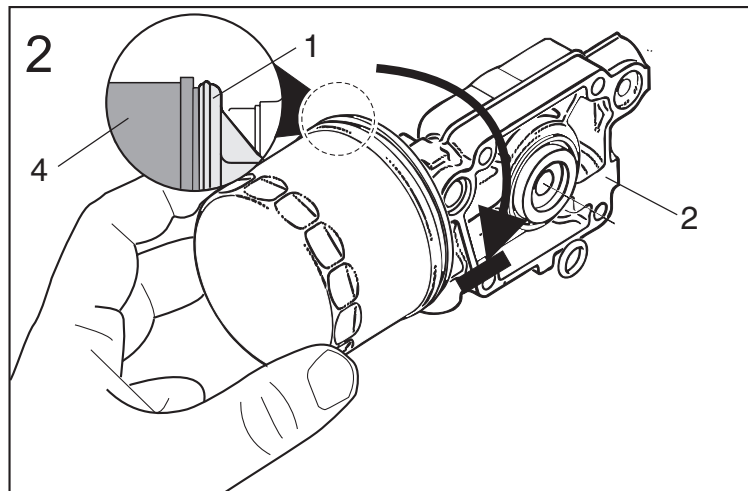
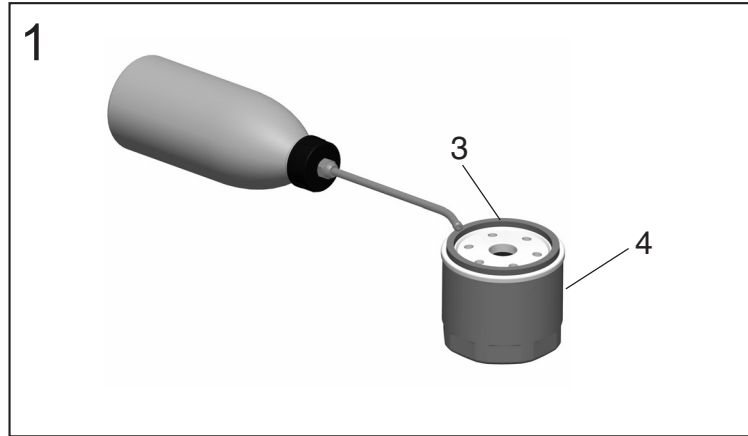

- 1 contact surface
- 2 oil pump housing
- 3 gasket
- 4 oil filter

08197

◆ NOTE: The illustrations in this document show the typical construction. They may not represent full detail or the exact shape of the parts which have the same or similar function. Exploded views are **no technical** drawings and are for reference only. For specific detail, refer to the current documents of the respective engine type.